

# JOHANNUS

*SCHEMATIC DIAGRAMS*

*S W E L L I N C K I*

ALTERATIONS RESERVED

JOHANNUS Orgelbouw b.v.

Morsestraat 28 - 6716 AH Ede - Tel. (08380) 37403 - Fax (08380) 22238

# C O N T E N T S

1. BLOCK DIAGRAM
2. POSITION DIAGRAM CARDS (TOPVIEW) & EXTERNAL CONNECTIONS (mounted on the rearside of the organ)
3. PINNING BUS CARD CONNECTORS
4. TRANSFORMER CONNECTIONS & POWER SUPPLY
5. SCANNING KEYING & TRANSPOSER
6. STOP-BANK & SWITCH-BANK CAPTURE SYSTEM
7. CAPTURE SYSTEM
8. PROCESSOR CARD
9. GENERATOR CARD
10. VOICE CARD
11. VOLUMECONTROLS; HEADPHONES CONNECTIONS & ECHO INTERFACE (ota card)
12. EXPRESSION PEDAL CIRCUIT (ota card)
13. AMPLIFIER CARD
14. POSITION DIAGRAM ADJUSTMENTS  
INTERNAL POTENTIOMETERS

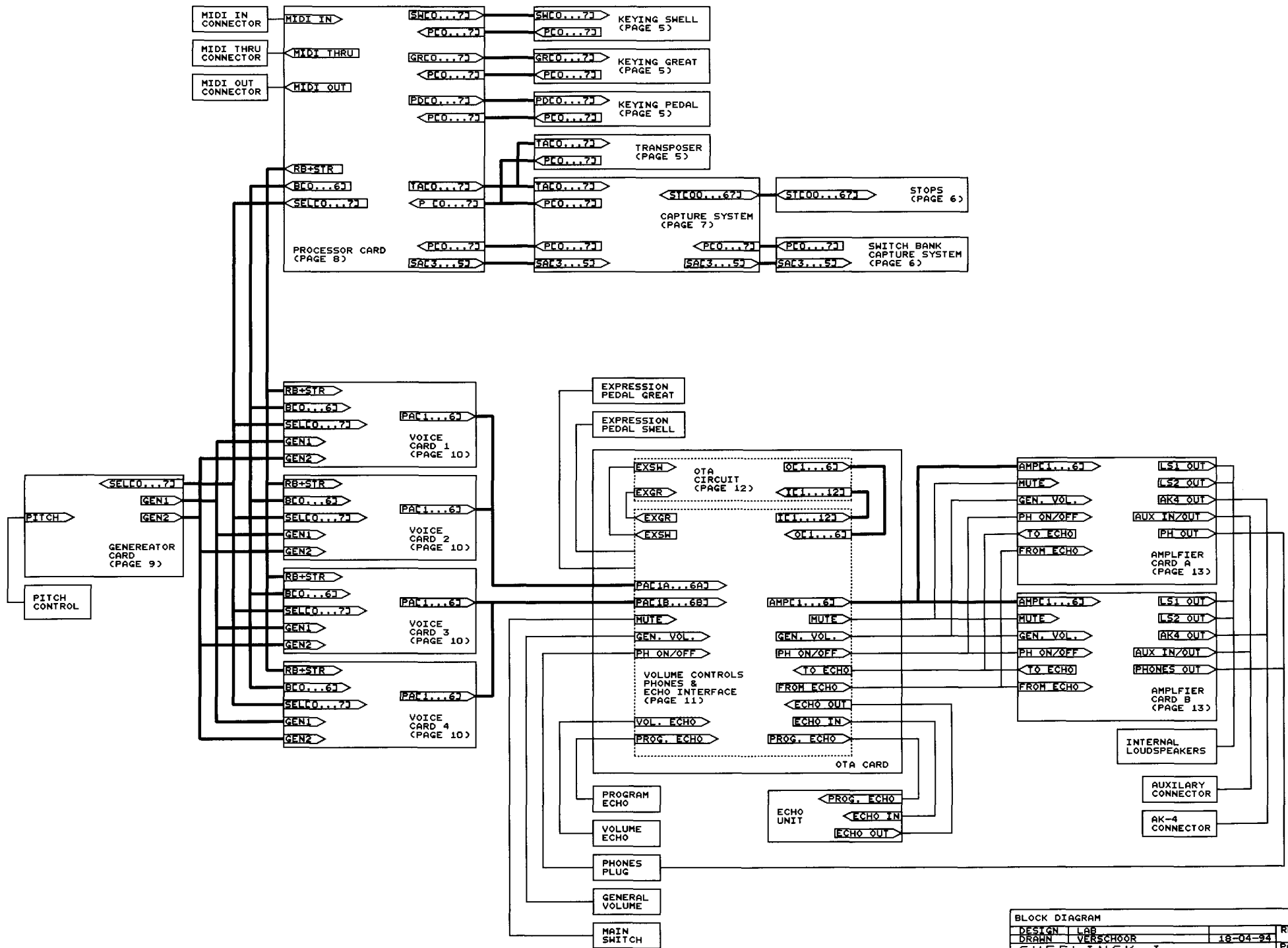

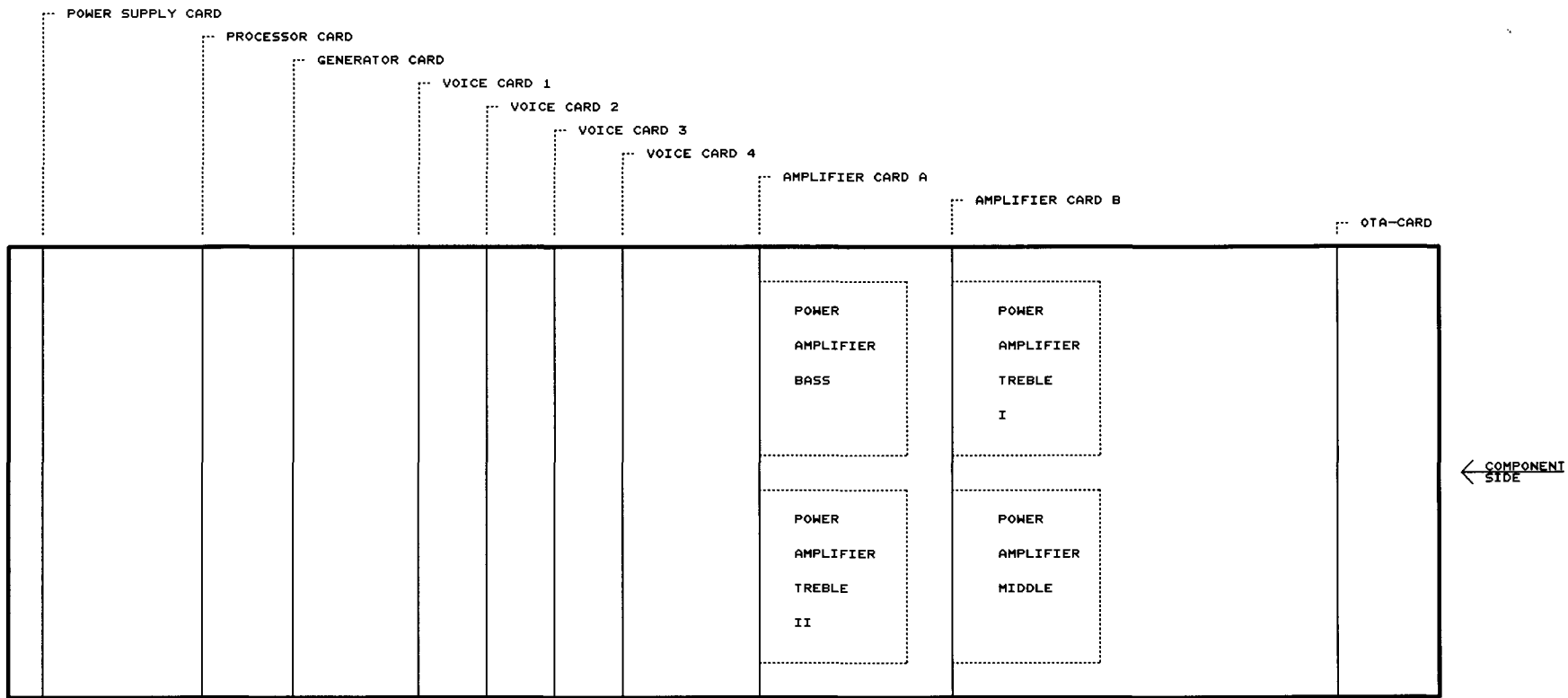

1. NOT CONNECTED
2. NOT CONNECTED
3. NOT CONNECTED
4. +5V MIDI IN
5. MIDI IN

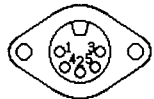

MIDI IN

1. NOT CONNECTED
2. NOT CONNECTED
3. NOT CONNECTED
4. +5V MIDI THRU
5. MIDI THRU

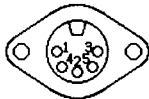

MIDI THRU

1. NOT CONNECTED
2. NOT CONNECTED
3. NOT CONNECTED
4. +5V MIDI OUT
5. MIDI OUT

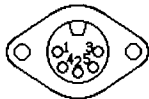

MIDI OUT

SOLDERINGSIDE VIEW

1. AK-4 OUT CHANNEL A
2. GROUND
3. NOT CONNECTED
4. AK-4 OUT CHANNEL B
5. NOT CONNECTED



AK-4  
OUT

1. AUX OUT CHANNEL A
2. GROUND
3. AUX IN CHANNEL A
4. AUX OUT CHANNEL B
5. AUX IN CHANNEL B



AUX  
IN/OUT

1. - BASS AMPLIFIER
2. + BASS AMPLIFIER
3. - MIDDLE AMPLIFIER
4. + MIDDLE AMPLIFIER
5. - TREBLE I AMPLIFIER
6. + TREBLE I AMPLIFIER
7. - TREBLE II AMPLIFIER
8. + TREBLE II AMPLIFIER

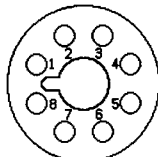

(OPTIONAL)

POSITION DIAGRAM CARDS (TOPVIEW) & EXTERNAL CONNECTIONS (mounted on the reverse side of the organ)			
DESIGN	LAB	REV.	
DRAWN	VERSCHOOR	18-04-94	PAGE 2
SWEELINCK I			

CON1	CON2	CON3	CON4-5	CON6-8	CON9-10	CON11	CON12
010 020 030 040 +12V 050 -12V 060 AGND 070 AGND 080 +35V 090 -35V 010 0110 0120 0130 0140 0150 0160 0170 0180 0190 0200 0210 0220 0230 0240 +5V 0250 LGND 0260 LGND 0270 0280 0290 0300 0310 0320 POWER SUPPLY CARD	010 020 030 040 +12V 050 -12V 060 AGND 070 AGND 080 +35V 090 -35V 010 0110 0120 0130 0140 0150 0160 0170 0180 0190 0200 0210 0220 0230 0240 +5V 0250 LGND 0260 LGND 0270 0280 0290 0300 0310 0320 PROCESSOR CARD	010 020 030 040 +12V 050 -12V 060 AGND 070 AGND 080 +35V 090 -35V 010 0110 0120 0130 0140 0150 0160 0170 0180 0190 0200 0210 0220 0230 0240 +5V 0250 LGND 0260 LGND 0270 0280 0290 0300 0310 0320 GENERATOR CARD	010 PA1B 020 PA3B 030 PA5B 040 +12V 050 -12V 060 AGND 070 AGND 080 +35V 090 -35V 010 0110 0120 0130 0140 0150 0160 0170 0180 0190 0200 0210 0220 0230 0240 +5V 0250 LGND 0260 LGND 0270 0280 0290 0300 0310 0320 VOICE CARD 1-2	010 PA1A 020 PA3A 030 PA5A 040 +12V 050 -12V 060 AGND 070 AGND 080 +35V 090 -35V 010 0110 0120 0130 0140 0150 0160 0170 0180 0190 0200 0210 0220 0230 0240 +5V 0250 LGND 0260 LGND 0270 0280 0290 0300 0310 0320 VOICE CARD 3-5	010 AMP1 020 AMP3 030 TO ECHO 040 +12V 050 -12V 060 AGND 070 AGND 080 +35V 090 -35V 010 0110 0120 0130 0140 0150 0160 0170 0180 0190 0200 0210 0220 0230 0240 +5V 0250 LGND 0260 LGND 0270 0280 0290 0300 0310 0320 AMPLIFIER CARD A & B	010 AMP2 020 AMP4 030 FROM ECHO B 040 FROM ECHO A +12V 050 -12V 060 AGND 070 AGND 080 +35V 090 -35V 010 0110 0120 0130 0140 0150 0160 0170 0180 0190 0200 0210 0220 0230 0240 +5V 0250 LGND 0260 LGND 0270 0280 0290 0300 0310 0320 AMPLIFIER CARD C	010 AMP1 020 AMP3 030 AMP5 040 FROM ECHO A +12V 050 -12V 060 AGND 070 AGND 080 +35V 090 -35V 010 0110 0120 0130 0140 0150 0160 0170 0180 0190 0200 0210 0220 0230 0240 +5V 0250 LGND 0260 LGND 0270 0280 0290 0300 0310 0320 OTA CARD

only CON6

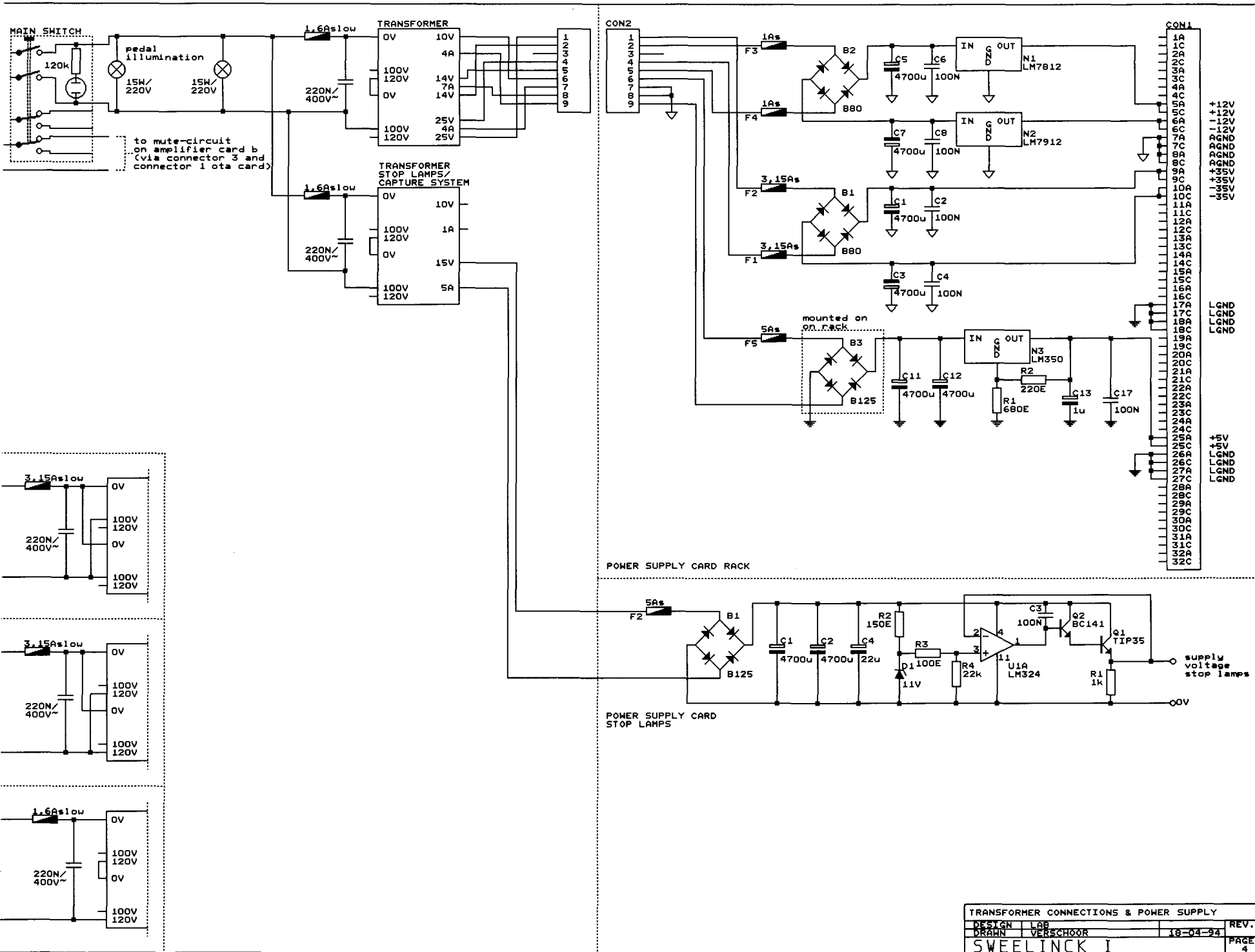

TRANSFORMER CONNECTIONS & POWER SUPPLY			
DESIGN	LAB		REV.
DRAWN	VERSCHOOR	18-04-94	PAGE
SWEELINCK I			4

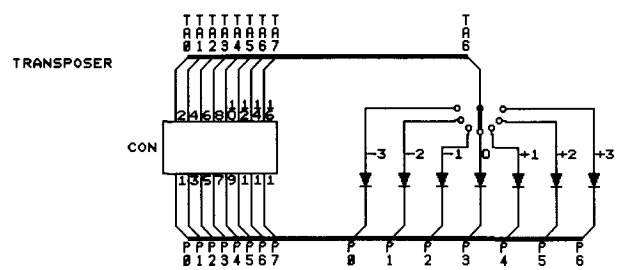
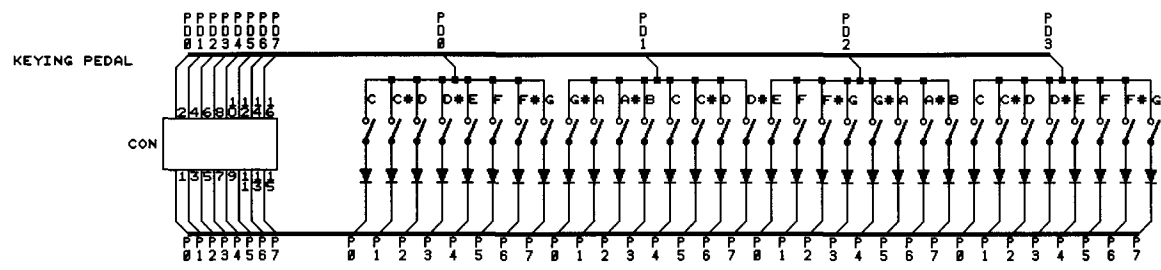
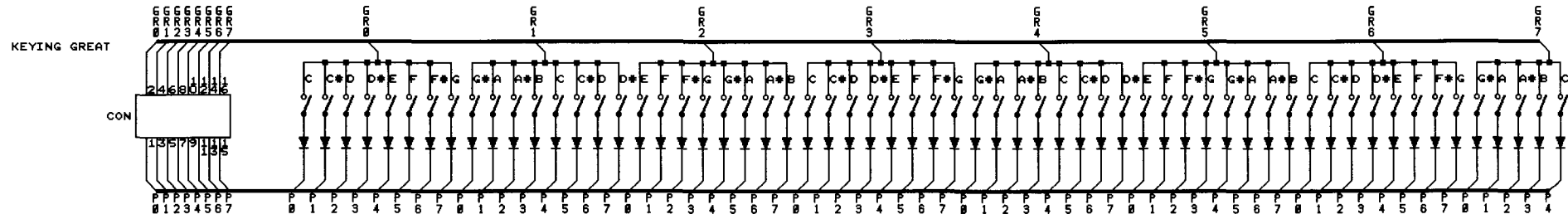
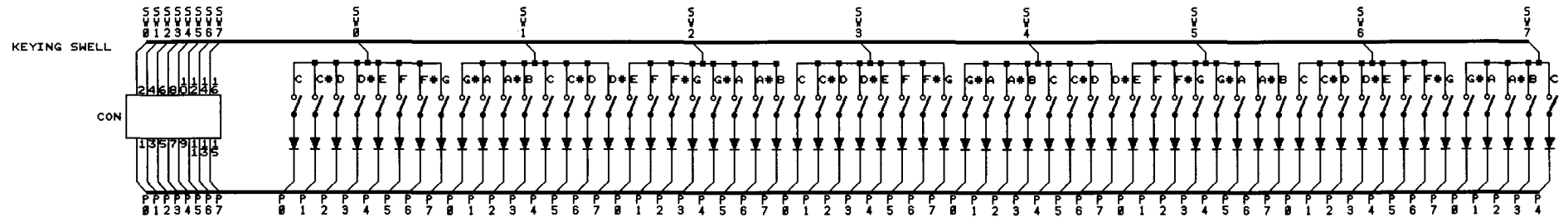

ALL CONNECTORS: TO PROCESSOR CARD  
ALL DIODES: 1N4148

SCANNING KEYING & TRANSPOSER			
DESIGN	LAB		REV.
DRAHN	VERSCHOOR	18-04-94	PAGE
SWEELINCK I			5

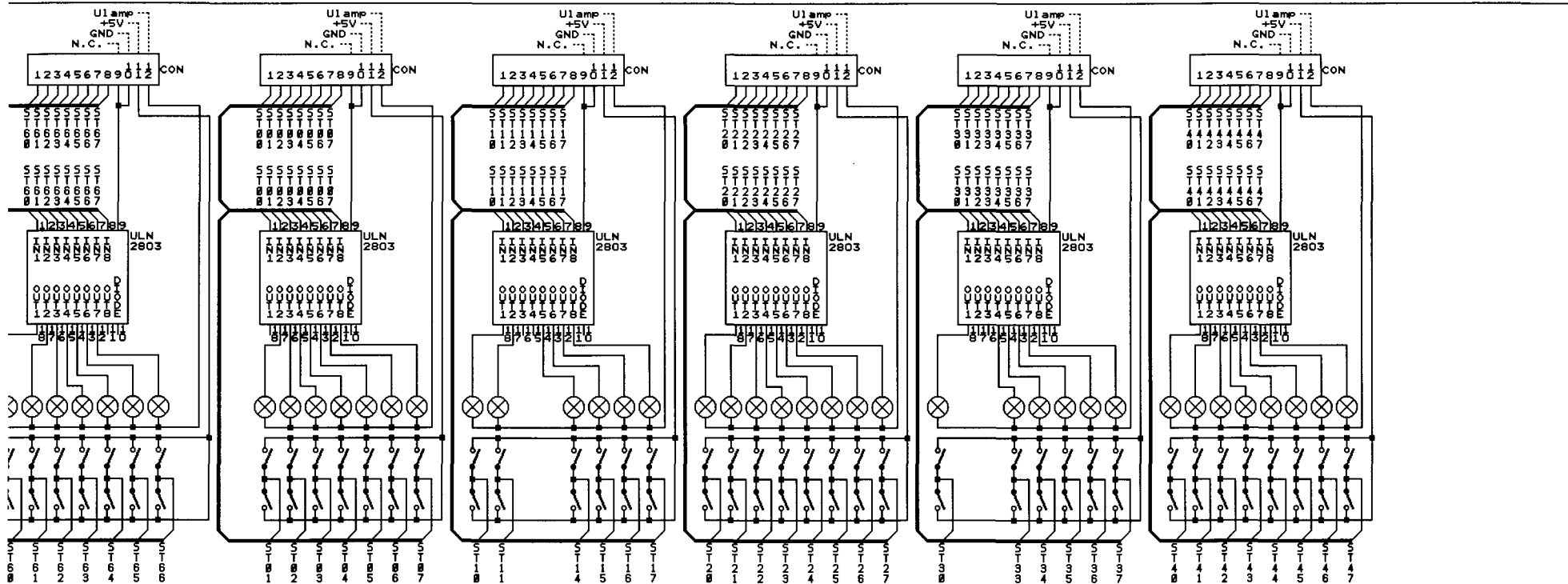

SWITCH-BANK CAPTURE SYSTEM

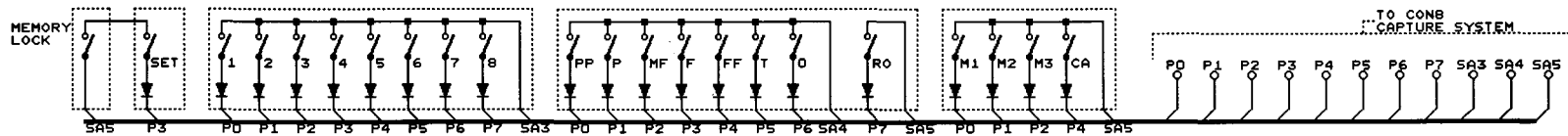

TO COMB CAPTURE SYSTEM

- |                                                                                                                                                                                                                                                                                 |                                                                                                                                                                                                                                                                                                                                                   |                                                                                                                                                                                                                                                                                                                                                                                                                                                                   |                                                                                                                                                                                                                                                                                                                                                                                                                                                                    |                                                                                                                                                                                                                                                                                                                                                                                                                                                                    |
|---------------------------------------------------------------------------------------------------------------------------------------------------------------------------------------------------------------------------------------------------------------------------------|---------------------------------------------------------------------------------------------------------------------------------------------------------------------------------------------------------------------------------------------------------------------------------------------------------------------------------------------------|-------------------------------------------------------------------------------------------------------------------------------------------------------------------------------------------------------------------------------------------------------------------------------------------------------------------------------------------------------------------------------------------------------------------------------------------------------------------|--------------------------------------------------------------------------------------------------------------------------------------------------------------------------------------------------------------------------------------------------------------------------------------------------------------------------------------------------------------------------------------------------------------------------------------------------------------------|--------------------------------------------------------------------------------------------------------------------------------------------------------------------------------------------------------------------------------------------------------------------------------------------------------------------------------------------------------------------------------------------------------------------------------------------------------------------|
| <p><b>STOPLIST</b></p> <ul style="list-style-type: none"> <li>ST60 = SWELL TO GREAT</li> <li>ST61 = GREAT TO PEDAL</li> <li>ST62 = SWELL TO PEDAL</li> <li>ST63 = TREMULANT GREAT</li> <li>ST64 = TREMULANT SWELL</li> <li>ST65 = CHORUS</li> <li>ST66 = MANUAL BASS</li> </ul> | <p><b>ACCESSORIES</b></p> <ul style="list-style-type: none"> <li>ST01 = DOUBLE BASS 16'</li> <li>ST02 = SUBBASS 16'</li> <li>ST03 = OCTAVE 8'</li> <li>ST04 = GEDACKT 8'</li> <li>ST05 = BASSFLUTE 4'</li> <li>ST06 = MIXTURE II</li> <li>ST07 = CONTRA TRUMPET 16'</li> <li>ST10 = TRUMPET 8'</li> <li>ST11 = MIDI TO PEDAL (CHAN. 3)</li> </ul> | <p><b>PEDAL</b></p> <ul style="list-style-type: none"> <li>ST14 = BOURDON 16'</li> <li>ST15 = OPEN DIAPASON 8'</li> <li>ST16 = ROHRFLUTE 8'</li> <li>ST17 = GAMBA 8'</li> <li>ST20 = OCTAVE 4'</li> <li>ST21 = OPEN FLUTE 4'</li> <li>ST22 = TWELFTH 2 2/3'</li> <li>ST23 = SUPEROCTAVE 2'</li> <li>ST24 = CONICAL FLUTE 2'</li> <li>ST25 = CORNET IV</li> <li>ST26 = MIXTURE IV-VI</li> <li>ST27 = TRUMPET 8'</li> <li>ST30 = MIDI TO GREAT (CHAN. 1)</li> </ul> | <p><b>GREAT</b></p> <ul style="list-style-type: none"> <li>ST33 = OPEN DIAPASON 8'</li> <li>ST34 = STOPPED FLUTE 8'</li> <li>ST35 = VIOLA 8'</li> <li>ST36 = CELESTE 8'</li> <li>ST37 = OCTAVE 4'</li> <li>ST40 = FLUTE 4'</li> <li>ST41 = FLUTE TWELFTH 2 2/3'</li> <li>ST42 = WALDFLUTE 2'</li> <li>ST43 = TIERCE 1 3/5'</li> <li>ST44 = RAUSCHPEIFE II-IV</li> <li>ST45 = CROMHNE 8'</li> <li>ST46 = OBOE 8'</li> <li>ST47 = MIDI TO SWELL (CHAN. 2)</li> </ul> | <p><b>SWELL</b></p> <ul style="list-style-type: none"> <li>ST33 = OPEN DIAPASON 8'</li> <li>ST34 = STOPPED FLUTE 8'</li> <li>ST35 = VIOLA 8'</li> <li>ST36 = CELESTE 8'</li> <li>ST37 = OCTAVE 4'</li> <li>ST40 = FLUTE 4'</li> <li>ST41 = FLUTE TWELFTH 2 2/3'</li> <li>ST42 = WALDFLUTE 2'</li> <li>ST43 = TIERCE 1 3/5'</li> <li>ST44 = RAUSCHPEIFE II-IV</li> <li>ST45 = CROMHNE 8'</li> <li>ST46 = OBOE 8'</li> <li>ST47 = MIDI TO SWELL (CHAN. 2)</li> </ul> |
|---------------------------------------------------------------------------------------------------------------------------------------------------------------------------------------------------------------------------------------------------------------------------------|---------------------------------------------------------------------------------------------------------------------------------------------------------------------------------------------------------------------------------------------------------------------------------------------------------------------------------------------------|-------------------------------------------------------------------------------------------------------------------------------------------------------------------------------------------------------------------------------------------------------------------------------------------------------------------------------------------------------------------------------------------------------------------------------------------------------------------|--------------------------------------------------------------------------------------------------------------------------------------------------------------------------------------------------------------------------------------------------------------------------------------------------------------------------------------------------------------------------------------------------------------------------------------------------------------------|--------------------------------------------------------------------------------------------------------------------------------------------------------------------------------------------------------------------------------------------------------------------------------------------------------------------------------------------------------------------------------------------------------------------------------------------------------------------|

ALL CONNECTORS: TO CAPTURE SYSTEM  
 ALL STOPLAMPS: 14Vdc/75mA

STOP-BANK AND SWITCH-BANK CAPTURE SYSTEM			
DESIGN	LAB	REV.	
DRAHN	VERSCHOOR	18-04-94	PAGE 6
SWEELINCK I			



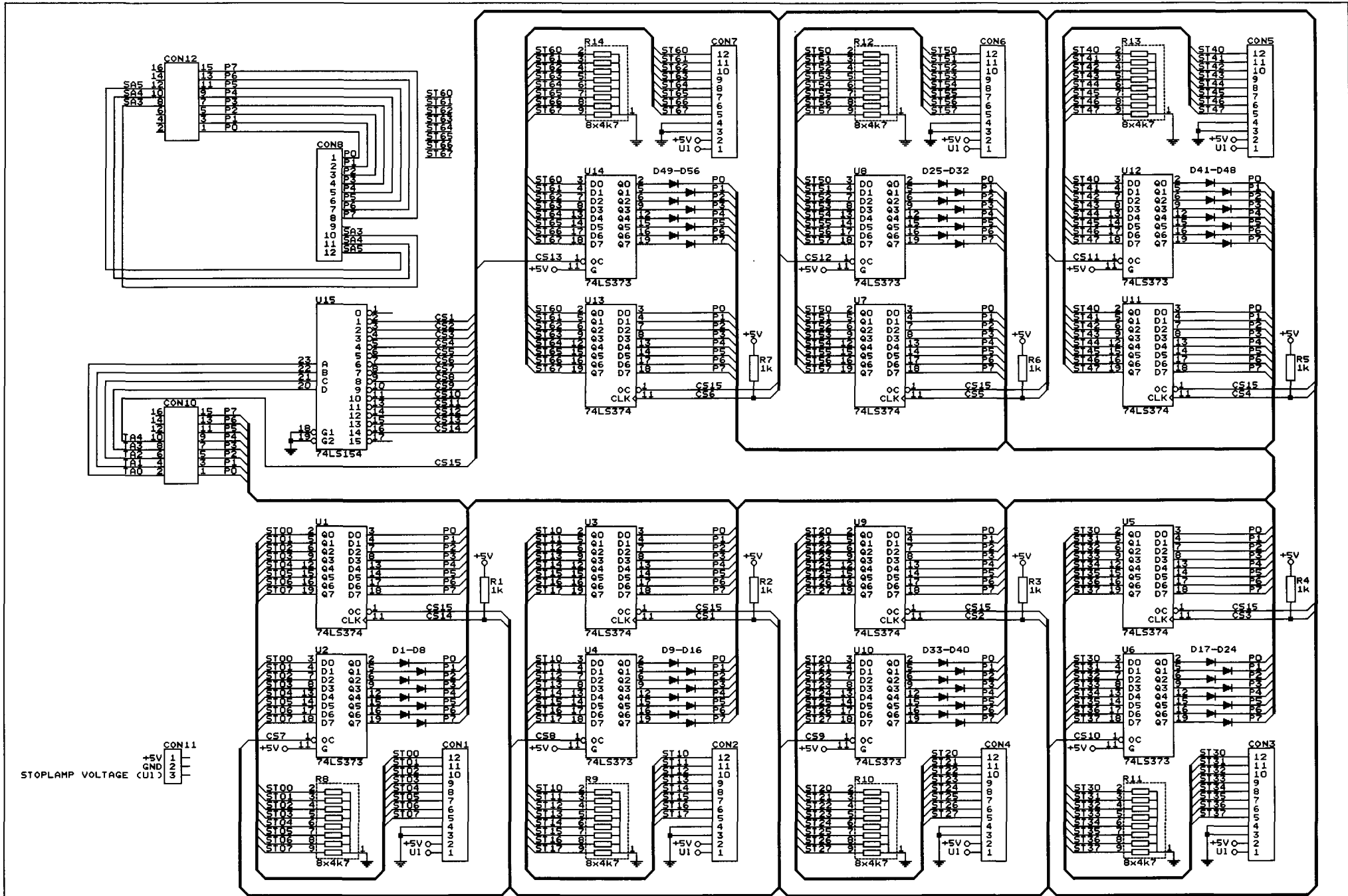

ALL DIODES: 1N4148

CAPTURE SYSTEM			REV.
DESIGN	LAB		18-04-94
DRAWN	VERSCHOOR		PAGE
SWEELINCK I			7

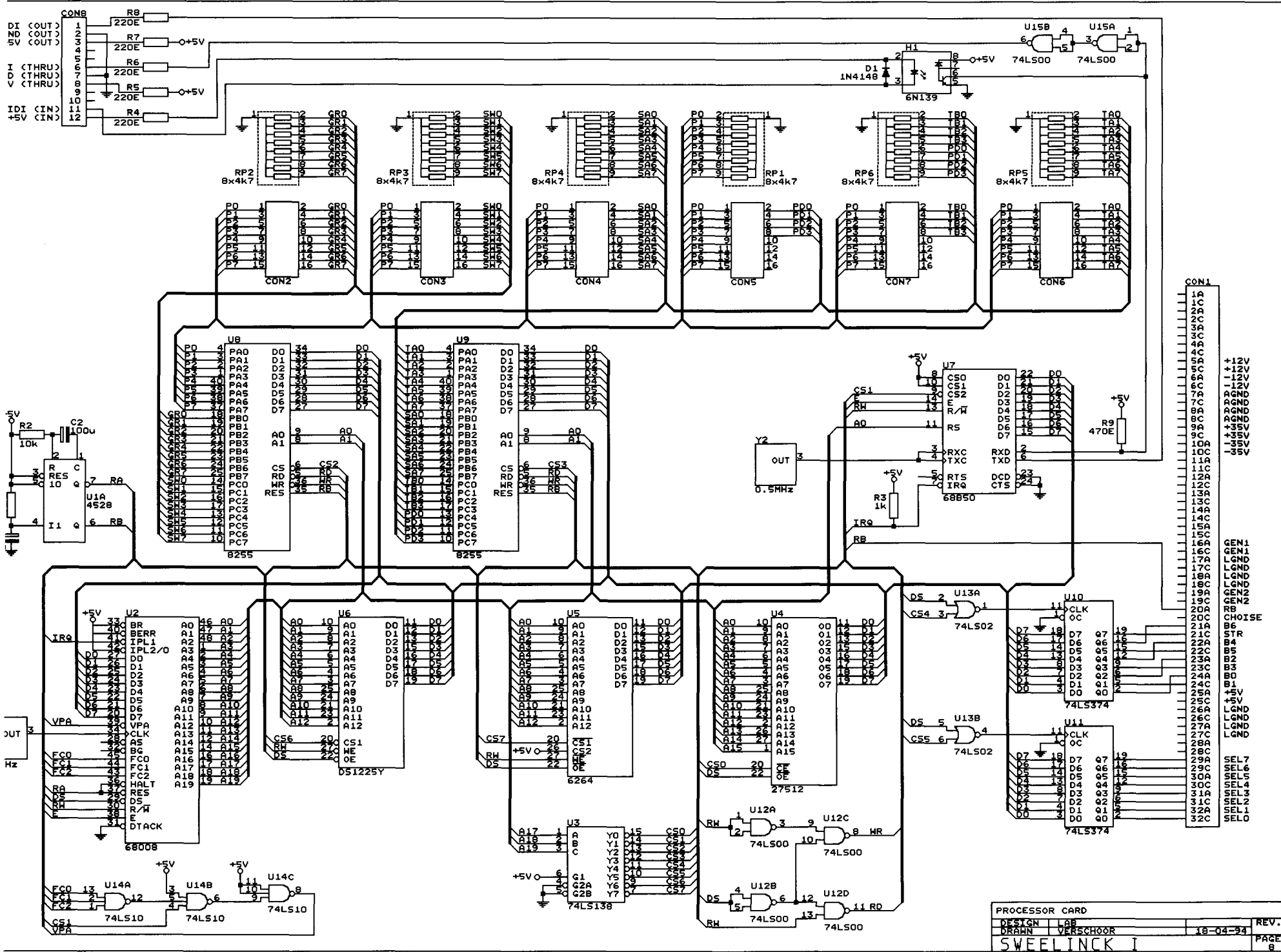

PROCESSOR CARD		
DESIGN	LAB	REV.
DRAWN	VERSCHOOR	18-04-94
SWEELINCK I		PAGE 6

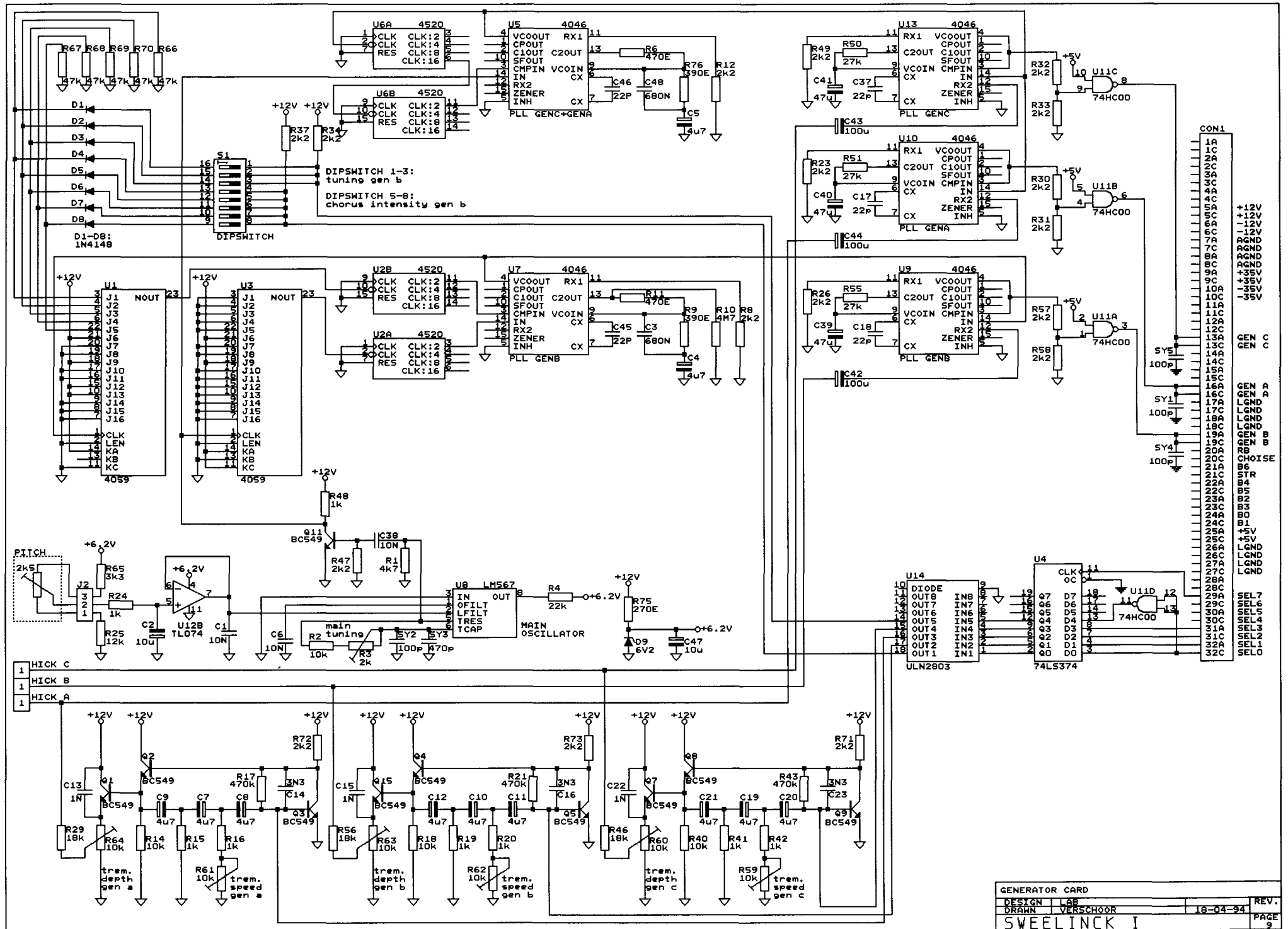

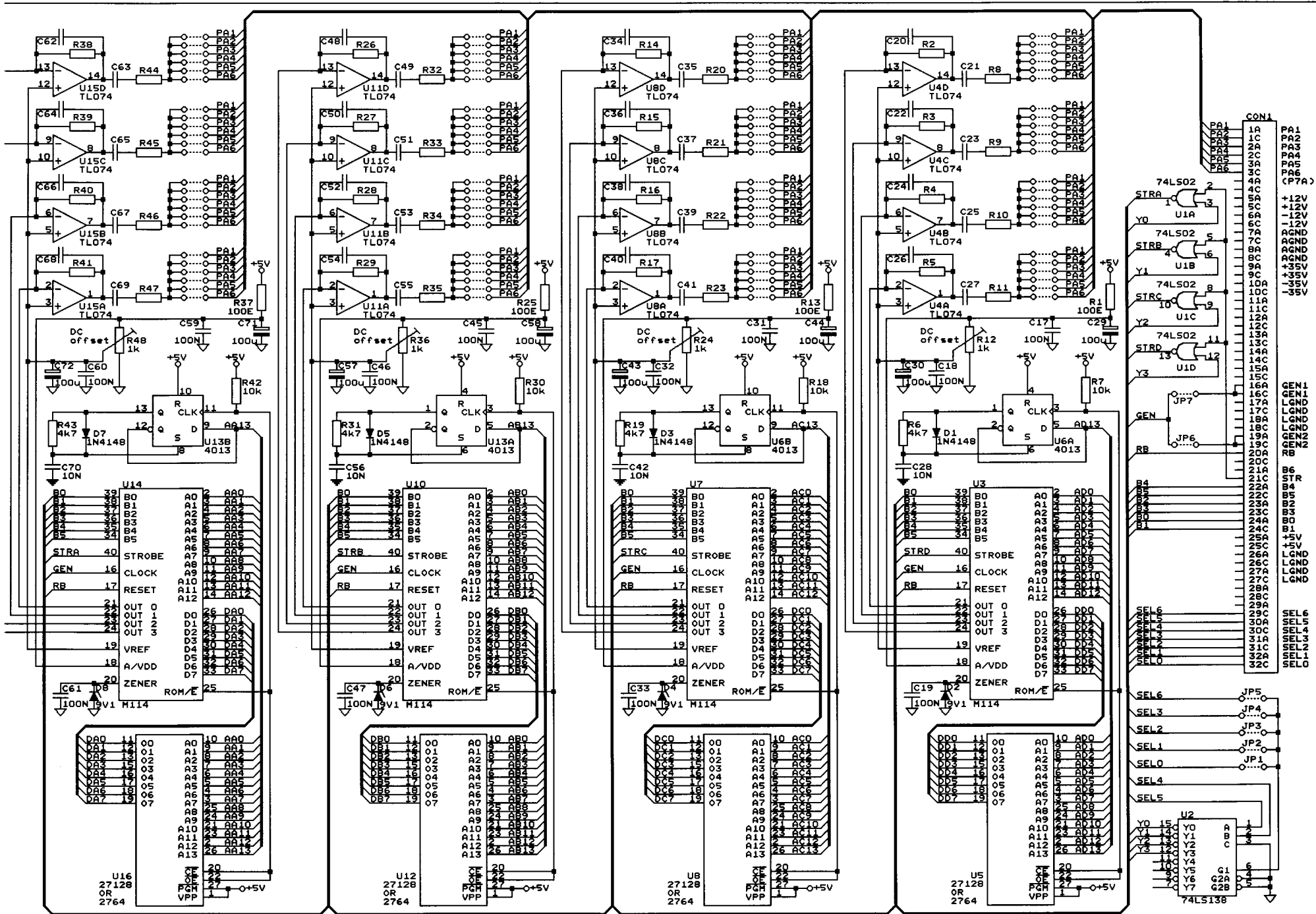

NOTE: IF FOR U5, U8, U12 OR U16 A 2764 EPROM IS PLACED INSTEAD OF A 27128 EPROM, THE 1/2 4013 (U6 AND U13) USED FOR SWITCHING THE UPPER 8K ROM AND THE LOWER 8K ROM, IS NOT NECESSARY.

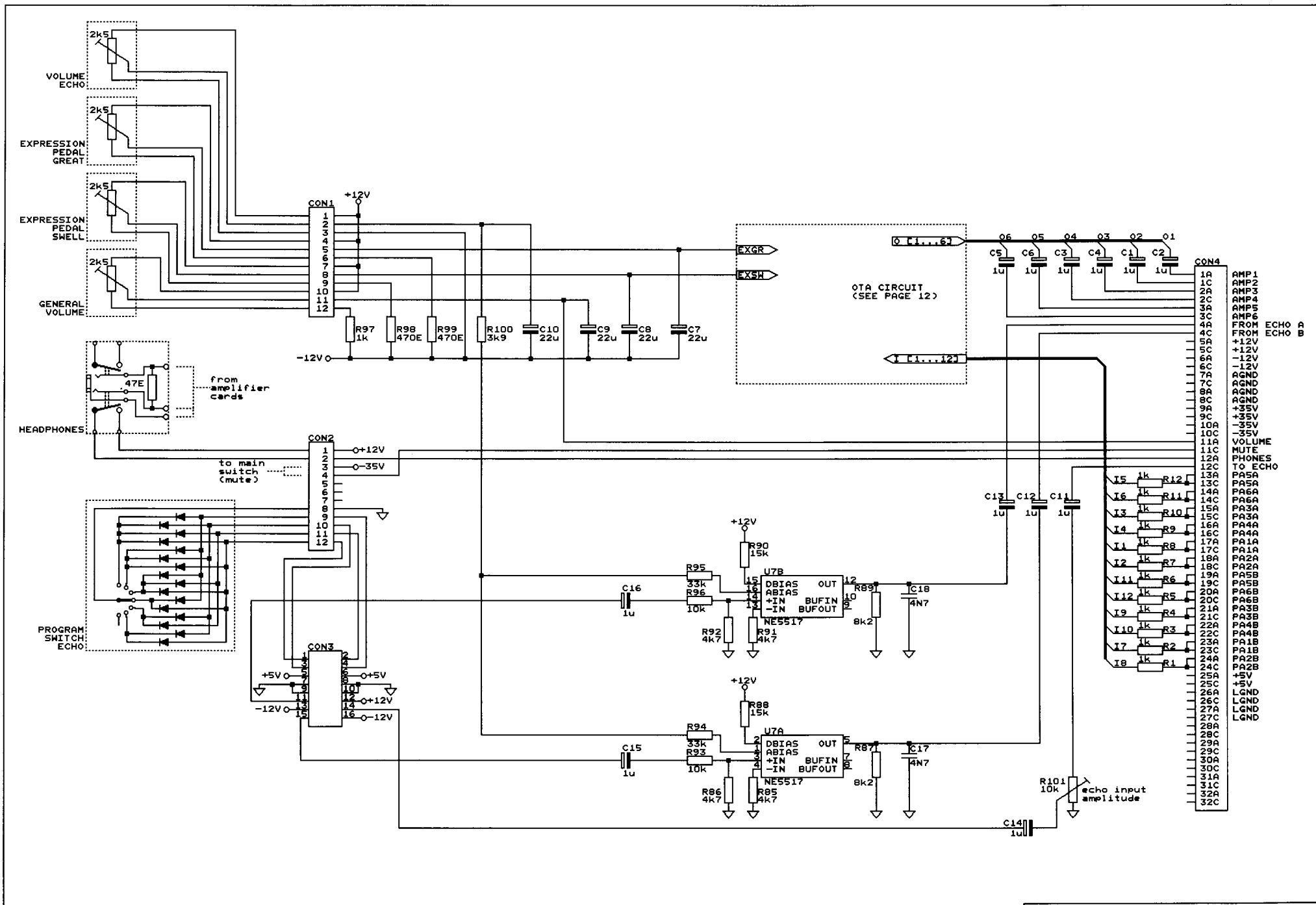

VOLUME CONTROLS: HEADPHONES CONNECTIONS & ECHO INTERFACE (ota card)

DESIGN LAB	REV.
DRANN VERSCHOOR	18-04-94
SWEELINCK I	PAGE 11

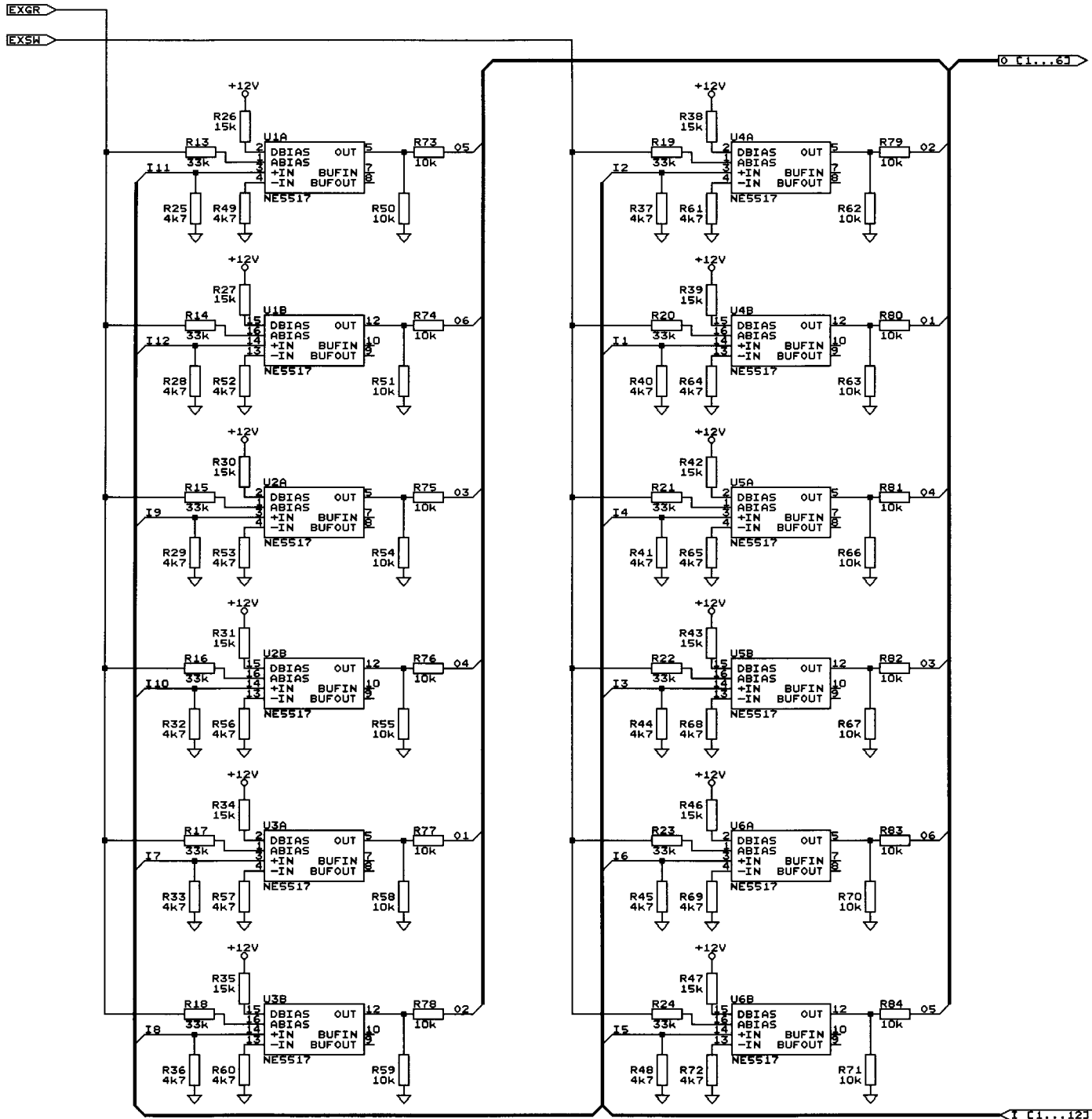

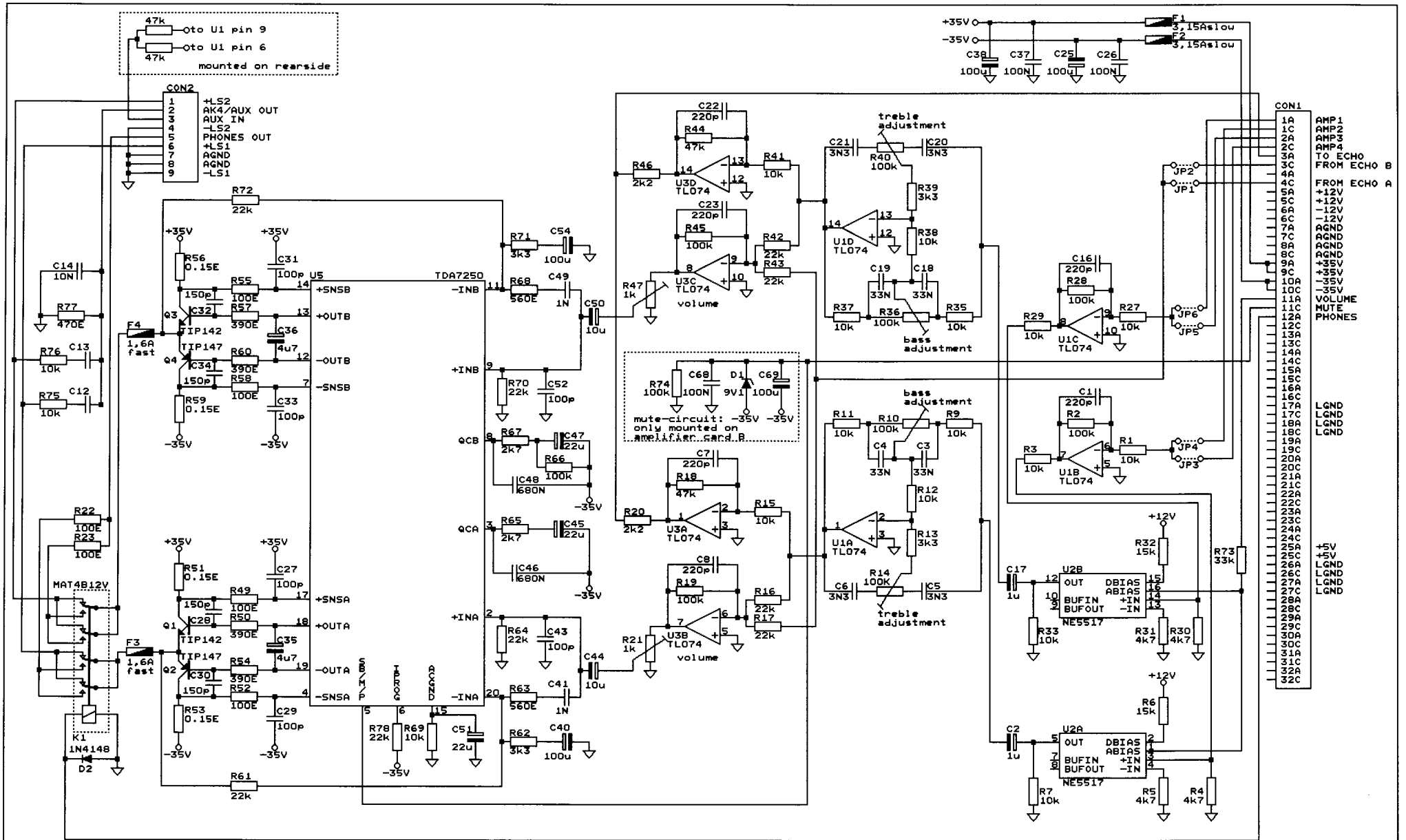

GENERATOR CARD  
(COMPONENT-SIDE VIEW)

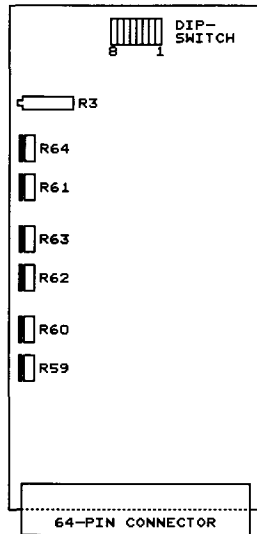

- R3 = MAIN TUNING
- R64 = TREMULANT DEPTH GREAT
- R61 = TREMULANT SPEED GREAT
- R63 = TREMULANT DEPTH SWELL
- R62 = TREMULANT SPEED SWELL
- R60 = TREMULANT DEPTH CHOIR
- R59 = TREMULANT SPEED CHOIR
- DS1-DS3 = TUNING SWELL
- DS4-DS8 = CHORUS INTENSITY SWELL

VOICE CARD  
(COMPONENT-SIDE VIEW)

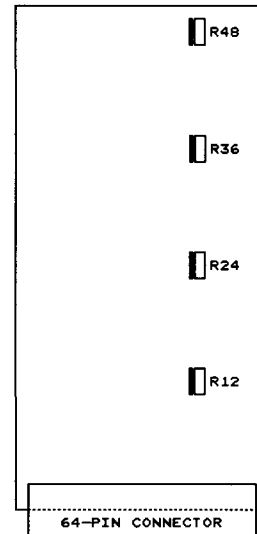

- R12 = DC-OFFSET VOICE D  
(DISTORSION VOICE D)
  - R24 = DC-OFFSET VOICE C  
(DISTORSION VOICE C)
  - R36 = DC-OFFSET VOICE B  
(DISTORSION VOICE B)
  - R48 = DC-OFFSET VOICE A  
(DISTORSION VOICE A)
- NOTE: R12-R24-R36-R48 ARE NOT  
FOR CHANGING VOLUMES!!  
TURNING THESE POTENTIOMETERS  
WILL GIVE DISTORSION!!

AMPLIFIER CARD  
(COMPONENT-SIDE VIEW)

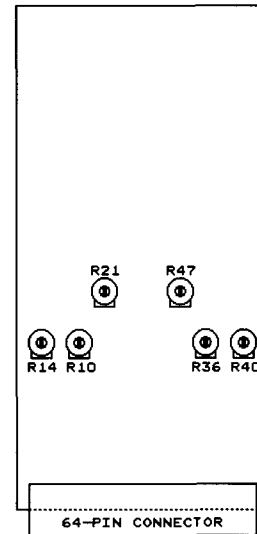

- R10 = BASS LEFT AMPLIFIER
- R14 = TREBLE LEFT AMPLIFIER
- R21 = VOLUME LEFT AMPLIFIER
- R36 = BASS RIGHT AMPLIFIER
- R40 = TREBLE RIGHT AMPLIFIER
- R47 = VOLUME RIGHT AMPLIFIER

OTA CARD  
(COMPONENT-SIDE VIEW)

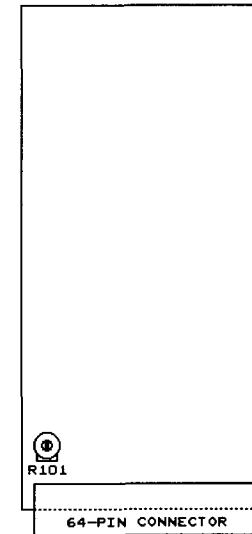

- R101 = INPUT AMPLITUDE ECHO